

INSTRUCTIONS FOR OPERATION AND CARE OF

SAMMONS
PRESTON

Rolyan®

SPLINT PANS
MODELS A426112 (SM-1501)
& A426110 (SM-1502)



A426112
(SM-1501)



A426110
(SM-1502)



PATTERSON
MEDICAL

SAMMONS®
PRESTON

1000 Remington Blvd • Suite 210 • Bolingbrook, IL 60440
1800-323-5547 • Canada call 1800-665-9200



ROLYAN SPLINT PANS

Rolyan Splint Pans are made out of durable stainless steel to resist corrosion. The heating element has also been specially designed to insure even heating of the splinting material. Both models feature variable temperature settings, removable lid and a convenient drain. All Rolyan Splint Pans tank interiors are constructed of stainless steel which heats evenly and resists corrosion. Grounded hospital grade plugs and high heat safety switches are standard.

Model A426112 (SM-1501) has a spacious interior that accommodates splinting sheets up to 24" x 18" (61cm x 46cm).

Model A426110 (SM-1502) has a compact design that makes it universally ideal for clinical use. The unit accommodates sheets up to 19" x 11" (48cm x 28cm).

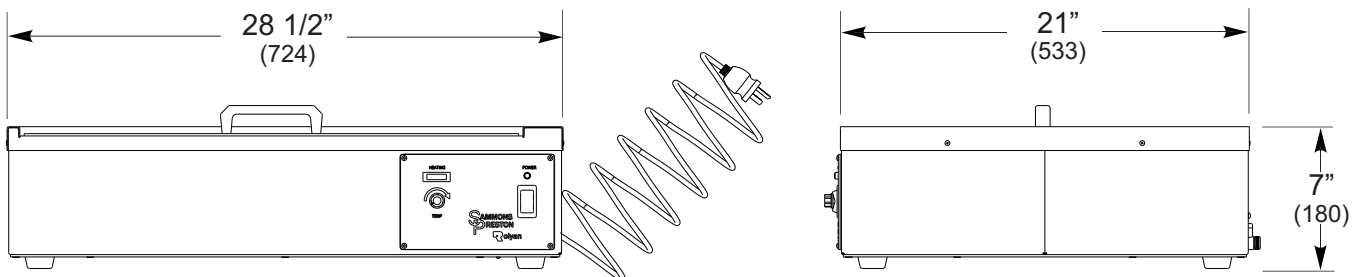
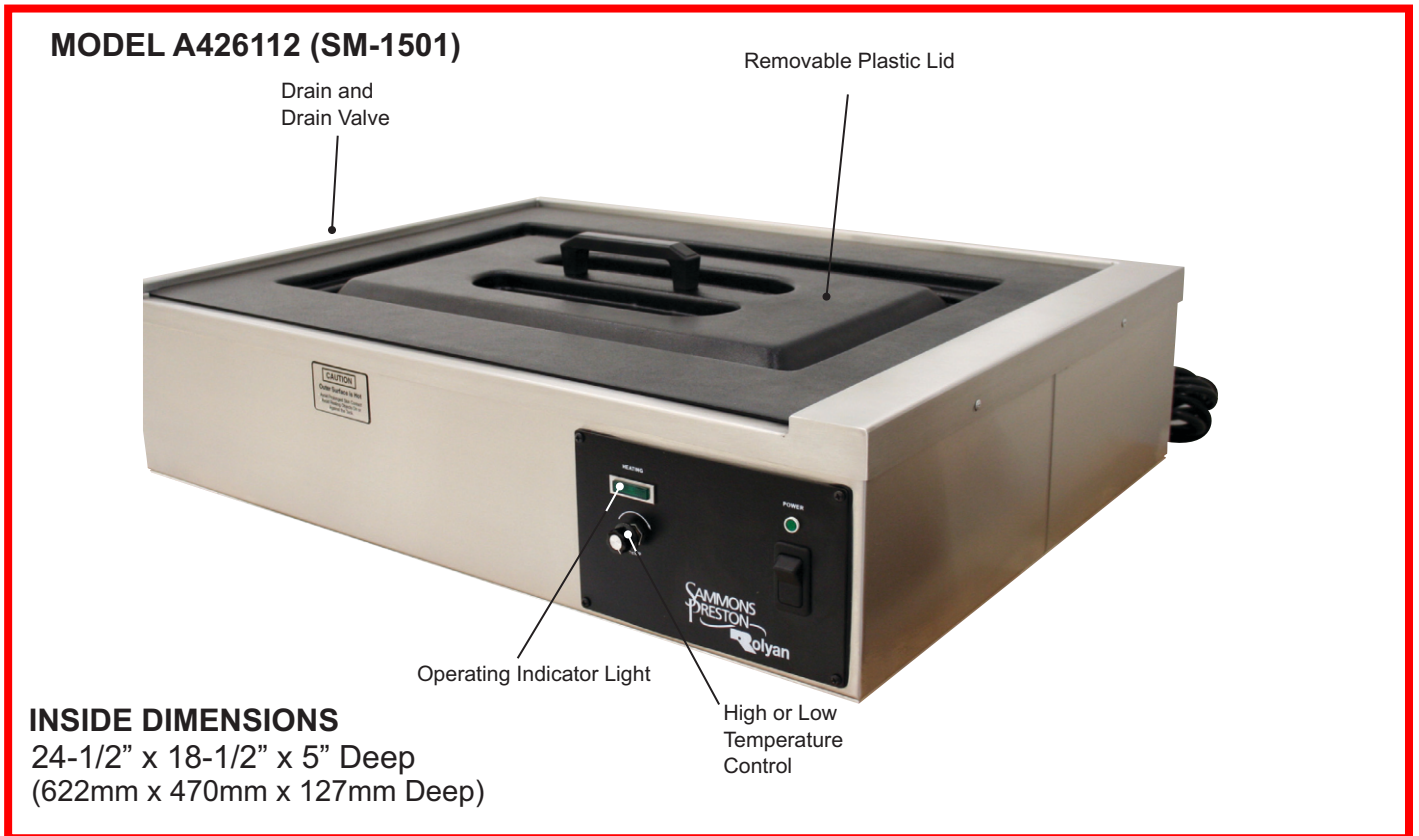



START UP PROCEDURES

Clean with Ready Metal. Let stand 30 minutes. Rinse with cold water and dry unit with rag or hair dryer. Fill with at least 3” of water before turning on unit.

INSTRUCTIONS FOR USE

- Place the splint pan on a secure platform, i.e., a table or big cart. Before filling with water, make sure the valve drain is in a closed position.
- Fill the unit with as much water as required. We would suggest at least 3”. Plug the unit in to a properly grounded outlet having a ground fault circuit interrupter either in the receptacle or somewhere in the immediate power line.
- On both models, the thermostat should be set to medium heat, which will closely approximate to 170° (76.6°C). Once the unit is turned on, allow the unit to reach temperature.
- With 3” of cold water and with the lid closing the top of the pan, operating temperature should be reached in approximately 90 minutes. To reduce the warm up time for all splint pans, use hot water.

Note: On all Rolyan Splint Pans, if possible, we recommend the use of deionized water to reduce the build-up of mineral deposits and dirt.

REMOVAL OF WATER

On the A426112 (SM-1501) and A426110 (SM-1502) models, cool the bath and slip the clear tube provided over the drain barb, open the valve and drain the water into a bucket, sink or drain.

CLEANING

STAINLESS STEEL

Clean weekly or more often, as needed (especially high-polish surfaces)

RECOMMENDED CLEANING MATERIALS

- Sponge - natural or artificial
- Nylon or other soft-bristle material brush
- SOFT cloth (as used on automobile finishes)

RECOMMENDED CLEANING SOLUTIONS

- Hand dishwashing liquid/soft water solution
- Mild soap/soft water solution
- 3M Stainless Steel Cleaner/Polish
- White vinegar/soft water solution (for brightening, removing oil deposit and hard water deposits)
- Club Soda and sponge

Note: High polish stainless steel surfaces should never come in contact with any abrasive cleaning brush, cloth or cleaning agent.

Wipe surfaces with CRES (available through Acorn) or equivalent cleaner. Apply using a soft non-abrasive cloth or sponge. Rinse surfaces thoroughly with clean water. Always follow cleaner/polish directions provided. Afterwards, using a soft, non-abrasive cloth, wipe surfaces with stainless steel cleaner/polish.

- CRES Cleaner specifically for rust stains (Available through Acorn)
- Tarn-X for general Stains
- #7 chrome polish
- Silver polish

To remove stubborn spots or to treat a scratch (Standard Satin Finish Only):

Use of synthetic, abrasive, general-purpose pads such as Scotch Brite® is recommended. Apply the stainless steel cleaner/ polish to the synthetic, abrasive pads and CAREFULLY rub out spot with cleaner/polish. *Be sure to rub in the direction of the grain!* Do not allow steel wool to come in contact with stainless steel. Steel particles can embed into the stainless steel surface and create rust!

SANITIZING THE BATH

It is the manufacturer’s opinion that the high heat levels of the baths - which approximate 175°F or higher - effectively sanitize the units, otherwise we the use of isopropyl alcohol for maximum disinfection.

But DO NOT use bleach, iodine or ammonia based disinfectants as such products will corrode the stainless steel.



TO CHANGE TEMPERATURE SETTINGS

On the A426112 (SM-1501) and the A426110 (SM-1502) the temperature is varied by turning the thermostat knob clockwise for an increase in temperature and counterclockwise for a decrease in temperature. The temperature on low setting should approximate 140°F and on high setting 190°F.

CHANGING THE OPERATING THERMOSTAT

Turn the splint pan off via the controls on the front panel and then unplug the unit. Allow the unit and the water to cool before draining the water from unit.

Both models have an operating thermostat, which allows for temperature modulation and an overheating sensor that prevents the pan from heating over 200°F. To replace the operating thermostat on the A426112 and A426110, pull the knob off the thermostat dial on the front of the unit and remove locking nut. Remove the four screws holding the front switch plate. Move this front switch plate to the side, allowing it to be supported by the wiring harness.

Follow the curled wire to the capillary tube and loosen the nut that clamps the capillary tube to the tank. Remove the capillary tube. Pull the wires off the thermostat and remove. To replace, put the wires onto the new thermostat and clamp the capillary tube to the tank. Screw the switch plate back onto the unit and put the locking nut and thermostat knob back in position. If there are any problems at all, please contact Sammons Preston.

CHANGING THE FUSE

Turn the splint pan off via the controls on the front panel and then unplug the unit. Allow the unit and the water to cool before draining the water from the unit.

Next, position the unit to allow access to the rear of the unit. Locate the fuse holders at rear of the unit near cord. Depress the fuse holder caps with the use of a “common” blade or fingers and rotate counterclockwise approximately 90° or until cap becomes loose. Remove the fuse holder cap, exposing the glass fuse. Remove the blown fuse.

Once the old fuse has been removed, replace it with a new fuse of the same kind and amperage. Re-install the fuse holder cap by depressing and rotating clockwise approximately 90° and ensure that the fuse holder caps are secured. Refill the splint pan with at least 3 inches of water and then plug the unit back into a power outlet. Turn the unit on via front control panel. Allow the water to warm up to the operating temperature and use as required.

REPAIR OF UNIT

In addition to the thermostat, which can be replaced on site, it may be necessary or you may desire to return the Sammons Preston Splint Pan for service to Sammons Preston. Please call this number and we will be glad to help you: (800) 432-2720



MODEL A426112 (SM-1501)

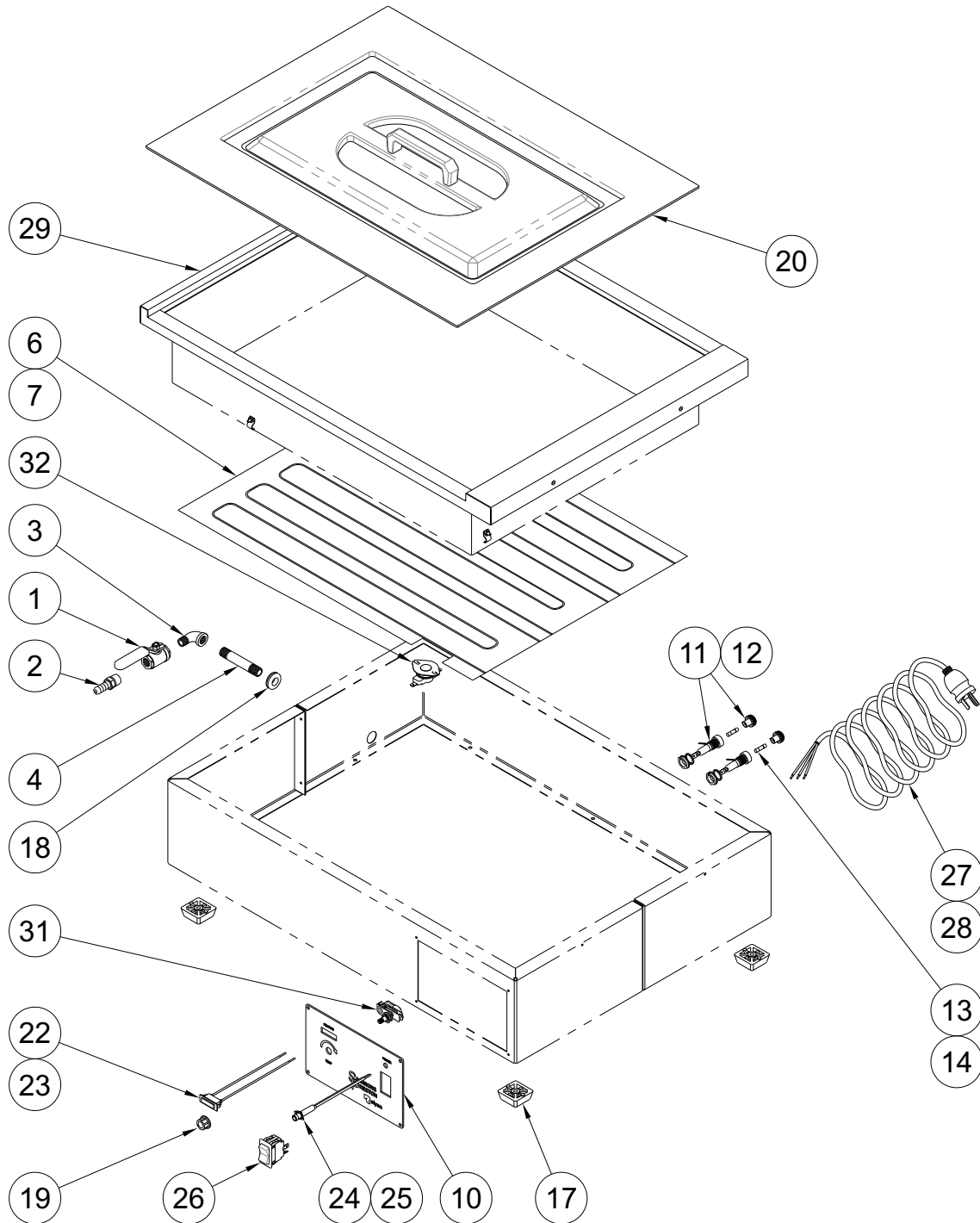



Address:

Patterson Medical Holdings, Inc
C/O Patterson Logistic Service, Inc.
1000 Remington Blvd Suite 210
Bolingbrook, IL 60440

Call toll free: 1-800-323-5547

In Canada call: 1-800-665-9200

Fax toll free: 1-800-547-4333

In Canada fax: 1-905-566-9207

Web: www.pattersonmedical.com

E-mail: CustomerSupport@Patterson-Medical.com



Authorized European Representative

Homecraft Rolyan

A Patterson Medical Company

Nunn Brook Road, Huthwaite

Sutton-In-Ashfield, Nottinghamshire NG17

2HU

United Kingdom

Phone: 08444 124 330

Fax: 08448 730 100

International

Phone: +44 1623 448 706

Fax: +44 1623 448 784