

**APPLICATION**

The Reliance 444 Single-Chamber Washer/Disinfector is intended for use in the cleaning and low-level disinfection of soiled reusable utensils, trays, glassware, bedpans and urinals, rubber and plastic goods, simple hard-surfaced rigid surgical instruments (such as forceps and clamps), and other similar and related items found in healthcare facilities.

**DESCRIPTION**

The Reliance 444 Single-Chamber Washer/Disinfector, a mechanical washer/disinfector, is equipped with an Eagle 3000 Stage 3 control system. The washer/disinfector is designed with seven factory set cycles: Instruments, Gentle, Utensils, Glassware, Plastic Goods, Anesthesia/Respiratory Goods and Decontamination. Three additional cycles are available for customized programming to meet specific operating requirements. Each preprogrammed cycle is equipped with Pre-Wash, Wash, Rinse and Thermal Rinse (including Drain Discharge Cool Down) phases.

The washer/disinfector is built to seismic design and includes a vented system and interior chamber light.

The washer/disinfector offers both manifolded and non-manifolded washing and a power vertical sliding door, in a single- or double-door configuration.

*NOTE: The Reliance 444 is available for use outside North America where 50 Hz power is supplied.*

**Size (W x H x L)**

Exterior dimensions:

- 42 x 80 x 32-5/8" (1067 x 2032 x 829 mm).

Chamber load capacity:

- 26-1/2 x 26-1/4 x 26" (673 x 667 x 660 mm).



Typical only - some details may vary.

Load height:

- 31" (787 mm) above finished floor.

**STANDARDS**

**The Reliance 444 Single-Chamber Washer/Disinfector meets the applicable requirements of the following standards:**

- Underwriters Laboratories (UL) Standard 61010-1
- Canadian Standards Association (CSA) CAN/CSA C22.2 No. 61010-1

**The Selections Checked Below Apply To This Equipment**

**POWER**

- Steam Heated
- Electric Heated

**POWER DOOR CONFIGURATION**

- Single
- Double

**VOLTAGE\***

**Steam Heated**

- 120/208 V, 60 Hz, 3-Phase, 4-Wire
- 380/400/415 V, 50 Hz, 3-Phase, 3-Wire
- 480 V, 60 Hz, 3-Phase, 3-Wire
- 600 V, 60 Hz, 3-Phase, 3-Wire

**Electric Heated**

- 380/400/415 V, 50 Hz, 3-Phase, 3-Wire
- 480 V, 60 Hz, 3-Phase, 3-Wire
- 600 V, 60 Hz, 3-Phase, 3-Wire

**ACCESSORIES†**

- Additional Peristaltic Pumps (Two Included)
- Condensate Return Cool Down (Steam Feature Only)
- Air Compressor
  - 110-115 V, 50/60 Hz
  - 200-240 V, 50/60 Hz
- Bottom Utility Connections
- Additional Chemical Pump for Enzyme Treatment
- Seismic Tie-Down Kit
- Multi-Voltage Transformer
- Remote Control 50' Extension (Load Side)
- Remote Control 50' Extension (Unload Side)

**OPTIONS‡**

- Pure Water Rinse
- Instrument Lubricant with Heated Pure Water Rinse

- Enzyme Treatment
- Non-Vented System with Dryer
- Non-Vented System without Dryer
- Vented System with Dryer
- Language Package
  - French
  - Spanish

\* Careful consideration should be given to voltage selection prior to ordering. Later changes require substantial field modification.

† See SD867 for material handling accessories.

‡ 50 Hz unit includes Enzyme Treatment Vented System with Dryer.

Item \_\_\_\_\_

Location(s) \_\_\_\_\_

## STANDARD FEATURES

---

**Vertical sliding power door(s)** is constructed of tinted, tempered glass with stainless-steel trim to allow the operator to view the chamber with the door closed. While a cycle is in progress, glass door remains cool to the touch.

Sliding door(s) is configured for power door operation. Door is opened and closed automatically using touch pads on the control panel, located on the same side of the washer/disinfector as the door being operated. Each power door includes a **safety sensor** to retract the door if an obstruction is detected in the doorway. If a power failure occurs, door(s) can be opened manually. The manual access handle is located on the top edge of the door and concealed behind the top service panel. If double power doors are ordered, a door interlock feature is provided to help prevent cross-contamination.

Stainless-steel pump is powered by a dual-speed motor. High pump speed provides the equivalent capacity of a 7.5 HP (5.6 kW) motor, 240 U.S. gal/min at 70 ft (910 L/min at 21.3 m) head pressure. Low pump speed provides the equivalent capacity of a 2 HP (1.4 kW) motor, 90 U.S. gal/min at 25 ft (341 L/min at 7.62 m) head pressure. Pump impeller is mounted directly on this motor shaft and does not require additional bearings. Pump motor is equipped with drip-proof frame, magnetic starter, overload protection and sealed bearing (requiring no periodic lubrication).

Pump, spray system and all recirculating piping are constructed of **stainless steel**.

**Rotary spray assemblies** are positioned (one at top and one at bottom of chamber) to reach all surfaces of the load. Depending on the accessory in the chamber, manifold connector automatically connects to the accessory at the start of each cycle.

**Heating coil (steam or electric)**, in the bottom of wash chamber (sump), raises and maintains water temperature to 140-180°F (60-82°C) during Wash phase and 180-203°F (82-95°C) during Thermal Rinse phase.

**Removable stainless-steel filters** in chamber sump prevent debris from entering the pump.

**16-W fluorescent light**, mounted within an explosion/vaporproof enclosure, illuminates the chamber interior.

**Wash chamber** is constructed of 16 gauge, #304 L (No. 4 finish) stainless steel, argon-welded. Chamber inhibits corrosive action of detergent and is easy to clean, with no enameled surfaces to chip or crack.

**Double-walled, insulated construction** of chamber exterior reduces heat loss and noise level to work area.

**Detergent injection pump** automatically dispenses a selected amount of liquid chemical (1/8 to 2 oz/U.S. gal; 1 to 16 mL/L) into the chamber sump during desired treatment. Tubing (50'/15 m), wiring, pick-up tubes, and low level sensors for remote location of chemical containers are included.

**Vented system** includes a 1/15 HP (50W) fan. Chamber vapors are exhausted to the building exhaust system through a 3" (76 mm) OD vent connection located on top of the chamber.

**Control panel**, mounted at eye level to the right of the chamber, allows easy monitoring of all cycle phases.

Control system includes seven pre-programmed cycles. Control can retain up to 10 processing cycles in memory, programmed and named according to Customer preferences. Once a cycle is started, programmed cycle values are locked in and cannot be changed until cycle is complete.

Control system is equipped with a Service Mode for preventive maintenance testing and to facilitate troubleshooting. A built-in service diagnostic program is included to permit system calibration and verification of component operations. Control also includes Cycle/Day Count Recall system to remind the operator when a complete preventive maintenance check is required.

**Decontamination cycle** is provided to prevent the formation of biofilm on the wash chamber and inside the piping, without the need for additional cycle programming.

**Priming cycle** is provided for automatic priming of chemical pump(s) on initial start-up of equipment, or as needed.

**Drain Discharge Cool Down** feature ensures water drained, at the end of each phase, from the chamber sump to building drain system does not exceed 140°F (60°C). If water temperature in the sump is greater than 140°F (60°C), cold water is automatically added to reduce water temperature being discharged to the building drain.

Piping, valves, electrical components, and wiring are easily accessible through **service access panels** (located on top and bottom of cabinet).

## CYCLE DESCRIPTION

---

**ADVISORY NOTE:** *Reliance 444 Single-Chamber Washer/Disinfectors are intended only to perform an initial step in the reprocessing of soiled, reusable medical devices. STERIS does not recommend, represent or warrant the Reliance Washer/Disinfector be used for the terminal disinfection or sterilization of any regulated medical device. If medical devices will be contacting blood or compromised tissues, such devices must be terminally reprocessed in accordance with current good hospital practices before each use in human patients.*

On initial daily start-up, setting the POWER-OFF/STANDBY switch to POWER prepares the washer/disinfector for cycle operation.

Once treatment cycle is selected, the washer/disinfector automatically processes the load through the following standard (additional phases are included in certain treatment cycles, depending on unit configuration) phases:

- **Pre-Wash:** Water (cold or hot) enters the sump from the building supply. Once the sump fills, pre-wash water is recirculated and sprayed over the load for the selected time interval (15 seconds to 15 minutes [2 to 15 minutes for Instrument, Anesthesia/Respiratory Goods and Gentle Cycles]). On completion of the phase, water is sent to the drain.
- **Wash:** Hot tap water enters the sump from the building supply, where a selected amount of detergent is added automatically. Detergent solution is heated and maintained

at a temperature ranging between 140 and 180°F (60 and 82°C). Once set temperature is reached, solution is recirculated and sprayed over the load for the selected time interval (2 to 15 minutes). On completion of the phase, solution is sent to the drain.

- **Rinse:** Hot tap water enters the sump from the building supply. Rinse water may be heated and maintained at a temperature ranging between 110 and 180°F (43 and 82°C). Once sump fills, rinse water is recirculated and sprayed over the load for the selected time interval (15 seconds to 15 minutes). On completion of the phase, water is sent to the drain.
- **Thermal Rinse:** Water (hot or optional purified) enters the sump from the building supply. Rinse water is heated and maintained at a temperature ranging between 180 and 203°F (82 and 95°C). Once set temperature is reached, rinse water is recirculated and sprayed over the load for the selected time interval (1 to 10 minutes). On completion of the phase, water is sent to the drain.

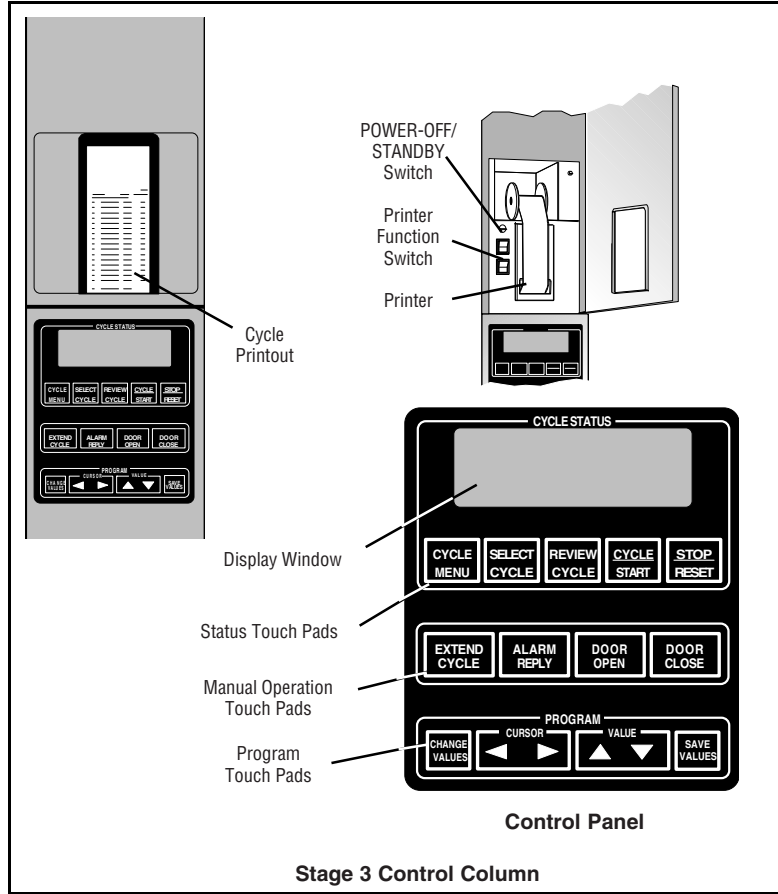

On completion of daily usage, washer/disinfector can be placed in a standby mode by setting POWER-OFF/STANDBY switch to the OFF/STANDBY position. Once the switch is set, there is a one-minute delay before the power door(s) automatically locks, and sump drains for two minutes.

## CONTROL SYSTEM

### Design Features

Microcomputers monitor and control washer/disinfector operations and functions. Cycle progresses automatically through the designated phases, as programmed.

Control system features **preprogrammed temperature ranges** for each cycle. If operator selects an out-of-range temperature setting when modifying the cycle values, control system alerts operator with reference message and halts further operation until correct value is entered.

Controls are housed in a vertical column, mounted to the right of the chamber. If double door option applies, controls are mounted in a vertical column to the right of the chamber on the load-side and the left of the chamber on the unload-side.

Features include:

1. **Hinged door at the top of load-side control column** provides access to:

- **POWER-OFF / STANDBY switch** includes two settings which direct operation of the control. Positioning switch to POWER initializes the controls and prepares washer/

disinfector for daily cycle operation; positioning switch to OFF/STANDBY places washer/disinfector in Standby mode and deactivates the main control panels.

- **Printer function switch** controls the following two printer functions:
  - » **Print** – pressing top of printer function switch generates a printout of the actual sump water temperature and actual chamber air temperature during optional drying phase.
  - » **Print Values** – pressing bottom of printer function switch generates a complete printout of all currently set cycles and cycle values.
- **Integral thermal printer:** provides an easy-to-read printed record of whether load was properly rinsed at the preset temperature, as well as a complete list of the alarm and abort in-cycle messages. Printer take-up spool automatically stores an entire roll of paper, providing cycle records which can be saved for future reference.
- 2. **Control panel,** consisting of a display window and three rows of membrane-type touch pads, is included on load-side and, if double-door option applies, unload-side control columns. Cycle initiation and cycle value programming can be performed from either control panel.
- **Display window** features a 2-line x 20-character, easy-to-read vacuum fluorescent display. Display shows cycle status, time, temperature, warnings and instructional messages. Display also indicates any abnormal conditions that may exist when a cycle is in progress. All

messages are complete readouts with no codes to be cross-referenced.

- **Status touch pads** allow operator to view available cycle menus, select a cycle, review a cycle before processing, and start, stop, and abort cycles.
  - **Manual operation touch pads** allow operator to double cycle time while reviewing cycle, acknowledge alarm conditions, and open and close power chamber door(s).
  - **Program touch pads** allow operator to bypass cycle phases and/or modify factory-set cycle values to meet specific operating needs. Available cycles, along with phase times and temperatures for each cycle, can be modified using CHANGE VALUES touch pad.
3. **Operator/Supervisor touch pad-selectable features** are accessible through either control panel.
- **Time display and printout units** permit selection of either Standard AM/PM or 24 hour military (MIL).

- **Security access code** requires entry of a four-digit access code in order to change cycles and cycle values. Pressing the CHANGE VALUES touch pad causes display to request entry of an access code. If access code is not properly entered, display advances to first cycle (and related cycle values) not requiring an access code.
- **Date and time** permits change of date and time.

### Technical Control Data

Control system consists of two microcomputer printed circuit boards located within the unit.

An **internal battery** backs up all cycle memory for up to 10 years. If a power failure occurs during a cycle, the control battery backup system ensures that cycle memory will be retained.

Even if the RAM battery should fail, factory-setting values are preserved in the control's main EPROM chip.

**Resistive Temperature Detectors (RTDs)** sense temperature inside the chamber. These signals, converted into electrical impulses, provide accurate control inputs and readouts throughout the entire cycle. Individual temperature calibrations can be made by a trained service technician.

**Water level sensor** monitors water level of the chamber sump. If water level and/or temperature sensor failure occurs, the alarm sounds and a message is printed.

**Printer board** has a 24-column, alphanumeric printer which produces characters within a five-by-seven dot matrix on 2-1/4" (57 mm) wide, single-ply thermal paper. Printer is controlled by a **dedicated microcomputer**. Print speed is approximately 48 lines per minute. Paper tape exits from an opening flush with the surface of the control panel and is taken up automatically by an idler spool mounted above the main printer assembly. Five paper tape rolls are furnished with each unit.

### SAFETY FEATURES

Washer/Disinfector is equipped with a **safety lockout feature** so cycle cannot start unless door is fully closed. If door is opened during a cycle, all utility services to chamber are shut off and cycle stops.

**Door interlock feature (power double doors only)** is provided to help prevent cross-contamination in a double door unit. Door interlock feature allows only one door to be opened at a time whenever power is on. When cycle is in process, door

```

*****
RELIANCE
MODEL 444
S/N 360000000
*****

V A L U E S

RELIANCE MODEL 444

2/09/10 8:52:16A

=====
= CYCLE PROGRAM REVIEW =
= CYCLE - INSTR. =
=====

REVIEW TIME 8:52:17A
REVIEW DATE 2/09/10
UNIT NUMBER 360000000
MOTOR SPEED = HIGH

PRE-WASH1
RECIRC. TIME= 2:00
WATER TEMP = COLD

ENZYME W.
SOAKING TIME= 1:00
WATER TEMP. = HOT

PUMP 1 WASH 1
RECIRC. TIME= 2:00
HEATED AT = 150.0F

RINSE 1
RECIRC. TIME= 0:15
WATER TEMP. = HOT

THERMAL
RECIRC. TIME= 1:00
HEATED AT = 180.0F

LUBRICANT P. WATER1
RECIRC. TIME= 0:10
HEATED AT = 150.0F
PURE H2O

DRYING
TIME= 7:00
HEATED AT = 240.0F

=====

=====
= CYCLE PROGRAM REVIEW =
= CYCLE - GENTLE =
=====

REVIEW TIME 8:52:20A
REVIEW DATE 2/09/10
UNIT NUMBER 360000000
MOTOR SPEED = LOW

PRE-WASH1
RECIRC. TIME= 2:00
WATER TEMP = COLD

ENZYME W.
SOAKING TIME= 1:00
WATER TEMP. = HOT

PUMP 1 WASH 1
RECIRC. TIME= 0:00
HEATED AT = 150.0F

RINSE 1
RECIRC. TIME= 0:15
WATER TEMP. = HOT

THERMAL
RECIRC. TIME= 1:00
HEATED AT = 180.0F

LUBRICANT P. WATER1
RECIRC. TIME= 0:10
HEATED AT = 150.0F
PURE H2O

DRYING
TIME= 7:00
HEATED AT = 240.0F

=====

```

Sample Printout — Factory-Set Cycle Values

interlock prevents either door from being opened without first pressing STOP/RESET touch pad.

A **main power ON/OFF switch**, located on the electrical supply box, must be used to shut off power to the unit before servicing.

## INSTALLATION

---

This unit is designed as a fully enclosed cabinet for freestanding or recessed installation. Clearance between top of unit and ceiling must be at least 13" (330 mm).

If unit is recessed through one or two barrier walls, stainless-steel barrier flanges are included to provide a finished wall appearance.

## OPTIONAL FEATURES

---

**Heated pure water rinse stainless- steel 316 valve** – pure water from building supply is sprayed through the spray system under pump pressure for 10 seconds. The effluent is not recirculated. (Spraying time may be adjusted from 10 seconds to 15 minutes. If time is adjusted to more than 10 seconds, water is recirculated.) Up to four pure water final rinse treatments can be selected per cycle (recirculated, and not recirculated). Pure water can be heated between 60 and 180°F (16 and 82°C) with either a steam or an electrical coil.

**Instrument lubricant with heated pure water rinse stainless-steel 316 valve** – a controlled quantity of lubricant is automatically added to pure water and sprayed (not recirculated) over the load for 10 seconds, or is heated and sprayed over the load and recirculated for the selected time interval (10 seconds to 15 minutes) during Pure Water Rinse phase.

**Enzyme treatment (60 Hz units only)** – following the Pre-Wash phase, load is sprayed (20 seconds) and soaked (with a mixture of enzyme detergent and warm water) to facilitate the breakdown of protein soils. This treatment can be removed.

**Non-vented system with dryer** – includes a 1/15 HP (50 W) fan and cold water condenser. Chamber vapors are exhausted through the condenser to the room. Drying system includes a 1.5 HP, 60 Hz (1.12 kW) - 1 HP, 50 Hz (0.75 kW) blower and three electric heaters, totaling 7.4 kW. System heats and maintains chamber air at a temperature ranging between 150 and 240°F (66 and 116°C). No additional duct work is required.

**Non-vented system without dryer** – includes a 1/15 HP (50 W) fan and cold water condenser. Chamber vapors are exhausted through condenser to the room. No additional duct work is required.

**Vented system with dryer (60 Hz units only)** – system (includes a 1.5 HP [1.12 kW], 60 Hz - 1 HP [0.75 kW], 50 Hz blower and three electric heaters, totaling 7.4 kW) heats and maintains chamber air at temperatures ranging between 150 and 240°F (66 and 116°C). Additional duct work is required. This treatment can be removed.

**Additional peristaltic pumps (two included)** – automatically add a selected quantity of detergent from 1/8 to 2 oz per U.S. gal (1 to 16 mL/L) to water during the Wash phase. Detergent

is pumped directly from the container. Low-level sensors are included to indicate when the detergent level in the containers is low. Additional peristaltic pumps may be used to program a second wash phase using acidic detergent. A second wash phase may be programmed in cycles 7 to 10.

**Condensate return cool down** – allows for connection of a steam condensate return outlet to the drain when condensate return line is not available in the building. Cold water is also injected in the drain piping when condensate return water temperature is too high. Condensate return cool down will keep the temperature in the drain piping below 140°F (60°C).

**Language package** – standard version is English. Control memory (display messages and printouts) and operator interface (control touch pads) are available in French or Spanish, if requested.

## ACCESSORIES\*

---

**Air compressor** – complete with automatic tank drain and pressure switch, see specifications on page 10.

**Bottom utility connections** – allow easy installation of utilities if supplied from the floor.

**Additional chemical pump for enzyme (60 Hz units only)** – this accessory must be purchased for Reliance 444 units without enzyme treatment option. Enzyme treatment allows the utilization of the MIS accessory. MIS accessory must be used only with the enzyme treatment.

**Seismic Tie-Down Kit** – unit is designed to comply with Seismic Zone 3 and 4 requirements and includes a seismic report for proper installing and securing of the washer to the building floor.

**Multi-voltage transformer** – required for facilities with 444 configuration operating on one of the following supply voltages:

- 240 V, 3-Phase, 3-Wire, 60 Hz, steam or electric heated;
- 600 V, 3-Phase, 3-Wire, 60 Hz, steam or electric heated;
- 208 V, 3-Phase, 4-Wire, 60 Hz, electric heated.

This transformer can only be used in combination with a 480 V, 3-Phase, 3-Wire, 60 Hz steam or electric heated washer.

**Remote Control 50' Extension** – permits control relocation up to 50' (15 m) away from washer/disinfecter (available for Load and Unload side).

\* See SD867 for information on Material Handling Accessories.

## PREVENTIVE MAINTENANCE

---

A global network of skilled service specialists can provide periodic inspections and adjustments to help ensure low-cost peak performance. STERIS representatives can provide information regarding the optional annual maintenance agreements.

## NOTES

---

1. Machine is shipped in one crate. Maximum size (W x H x L) is 50 x 91 x 42" (1270 x 2311 x 1067 mm).
2. Customer must ensure washer/disinfector stands on a noncombustible floor. (Floor should be level.)
3. STERIS recommends that shutoff valves and vacuum breakers (not provided by STERIS) be installed on service lines, and that disconnect switches (with lockout in OFF position; not provided by STERIS) be installed in electric supply lines near the equipment.
4. Pipe sizes shown indicate terminal outlets only. Building service lines (not provided by STERIS) must supply the specified pressures and flow rates.
5. For all ventilation ducting from washer/disinfector, STERIS recommends installation of a dedicated corrosion proof, watertight duct to the exterior of the building, sloped toward the washer. A 3" (76 mm) ID flexible duct is recommended.
6. Minimum ceiling height for removal of doors is 94" (2388 mm).
7. STERIS recommends illumination of the service area (if applicable) along with provision of a convenience power outlet for maintenance.

**The base language of this document is ENGLISH. Any translations must be made from the base language document.**

## UTILITY REQUIREMENTS

**Important: Refer to equipment drawing 920-014-342EN for installation details and specifications.**

### Hot Water

1/2" NPT; 15 dynamic to 50 static psig (103 to 345 kPa); 110°F (43°C) maximum. Minimum flow rate: 5.5 U.S. gpm (21 L/min); maximum flow rate: 9.3 U.S. gpm (35 L/min).

### Cold Water (if option applies)

1/2" NPT; 30 dynamic to 50 static psig (206-345 kPa); 60°F (16°C) maximum. Minimum flow rate: 10.3 U.S. gpm (39 L/min); maximum flow rate: 12.9 U.S. gpm (48.8 L/min).

### Steam (Steam-Heated Unit only)

1/2" NPT; 30-80 psig (206-550 kPa) dynamic; 185-400 lbs/hr (84-181 kg/hr). Peak flow rate: 210-470 lbs/hr (95-213 kg/hr). Maximum 90 psig (621 kPa) static.

### Condensate Return (Steam-Heated Unit only)

1/2" NPT. Peak flow rate: 1 U.S. gpm (4 L/min).

### Pure Water

1/2" NPT, 5 dynamic to 25 static psig (35-172 kPa). Minimum flow rate: 5.6 U.S. gpm (15.9 L/min). Recommended minimum specific resistivity of 0.1 megohm per cm.

### Air

1/8" NPT; 65 dynamic to 125 static psig (448 to 860 kPa). Flow rate: 1 scfm (0.03 m<sup>3</sup>/min). Maximum particle size: 40 micron. Maximum particle density: 10 mg/m<sup>3</sup>. Maximum dew point for water content: 45°F (7°C). Maximum oil concentration for all content: 25mg/m<sup>3</sup>, as per ISO-8573-1.

### Ventilation

3" (76 mm) O.D.; 75 scfm (2.123 m<sup>3</sup>/sec.).

### Drain

2" NPT; a 4" (102 mm) O.D. floor funnel or open drain, and 4" (102 mm) O.D. floor sink is recommended. Gravity drain maximum flow rate: 15 U.S. gpm (57 L/min). Pump drain maximum flow rate: 90 U.S. gpm (342 L/min).

### Electricity

3/4" (19 mm) conduit size; 1" (25.4 mm) if over 24 Amps.

### Electricity (Steam-Heated Unit) with Drying System

120/208 V, 60 Hz, 3-Phase, 4-Wire, 27 Amps; or 480 V, 60 Hz, 3-Phase, 3-Wire, 12.5 Amps; or 380/400/415 V, 50 Hz, 3-Phase, 3-Wire, 13 Amps; or 600 V, 60 Hz, 3-Phase, 3-Wire, 12 Amps.

### Electricity (Steam-Heated Unit) without Drying System

120/208 V, 60 Hz, 3-Phase, 4-Wire, 14.5 Amps; or 480 V, 60 Hz, 3-Phase, 3-Wire, 7 Amps; or 380/400/415 V, 50 Hz, 3-Phase, 3-Wire, 7 Amps; or 600 V, 60 Hz, 3-Phase, 3-Wire, 9 Amps.

### Electricity (Electric-Heated Unit) with or without Drying System

480 V, 60 Hz, 3-Phase, 3-Wire, 26.5 Amps; or 380/400/415 V, 50 Hz, 3-Phase, 3-Wire, 31 Amps; or 600 V, 60 Hz, 3-Phase, 3-Wire, 24 Amps.

## NOTES

1. On 380/400/415 V units, NPT fittings are replaced by BSPT.
2. Vent connection not required if non-vented vapor condenser option is selected.

**CUSTOMER IS RESPONSIBLE FOR COMPLIANCE WITH APPLICABLE LOCAL AND NATIONAL CODES AND REGULATIONS.**

## ENGINEERING DATA

Ship. Weight t lbs (kg)	Oper. Weight lbs (kg)	A-Weighted Equivalent Surface Sound Pressure Level*	Heat Loss BTU/hr (kJ/h) at 75°F (24°C) 40% RH Ambient		Water Consumption			Steam Consumption per Cycle†	Pure Water Consump. per Cycle‡
					Hot	Cold			
			Vented	Non-Vented		Vented System	Non-Vented System		
1075 (488)	1200 (544)	67.6 dB	1580 (1667)	7200 (7596)	37.8 (143)	38.2 (144.6)	80.9 (306.2)	40.3 (18.3)	12.6 (48)

## PRE-PROGRAMMED CYCLE PHASES AND APPLICATIONS

(Factory Settings – General Note: Treatment time does not include filling, heating and draining.)

	PRE-WASH (up to 4)	ENZYME TREATMENT				WASH (1 to 4)	RINSE (up to 4)	THERMAL RINSE	HEATED PURIFIED WATER RINSE LUBRICANT ‡ (up to 4)	DRYING
		Spray	Soak	Rinse	Rinse					
		Standard	Selectable							
<b>Time*</b>	2 min	20 sec.	1 min.	15 sec.	15 sec.	2 min.	15 sec.	1 min.	Recirculated 10 sec.	7 min.
<b>Temperature*</b>	Cold Tap Water	Hot Tap Water	N/A	Cold Tap Water	Cold Tap Water	Hot Tap Water Heated and Maintained at 150°F (82°C)‡	Hot Tap Water	Hot Tap§ Water Heated and Maintained at 180°F (82°C)‡	Pure Water Heated at 150°F (66°C)	Air Heated to 240°F (116°C) set point (not maintained)
<b>Pre-Programmed Cycles: Gentle Cycle</b>	X	X	X	X	X	8 min.	X	X	X	X
<b>Instruments</b>	X	X	X	X	X	X	X	X	X	X
<b>Glassware</b>	X					X	X	X	without lubricant	X
<b>Utensils</b>	X					X	X	X	without lubricant	X
<b>Anesthesia/ Respiratory Goods</b>	X					X	X	X		158°F (70°C)† for 60 min.
<b>Plastic Goods</b>	X					X	X	X		200°F (93°C)†
<b>Rigid MIS</b>	10 min.	X	5 min.	X	X	10 min.	X	X	X	240°F (116°C)† for 15 min.
<b>Decontamination</b>						15 min.	3 x 1 min.			30 min.

X Applicable

\* Control default times and temperatures given, selectable ranges on these cycles are operator controlled.

† Air heated to set point, not maintained.

‡ Selection indicates temperature at which sump water will be maintained. Temperature on items will be approximately 4°F (2°C) lower.

§ If pure water option is available, pure water and/or lubricant can be selected during thermal rinse phase.

## ENGINEERING DATA - RECOMMENDED TRANSFORMER

Power kVA	Input (HV) V 3 ~, 60 Hz	Output LV V 3 ~, 60 Hz	Weight	Noise Level dB	No Load Loss Watts	Load Loss 302°F (150°C)	Total Losses Watts
30	208/240/600	480	457 lbs (208 kg)	45	258	608	867

Excitation Current %	Installation	Size in. (mm) AWG	HV Connectors per phase AWG	LV Connectors per phase	Winding (HV) (LV)	Temperature Class °F (°C)
3.96	Wall/Floor	See Below	2.14	2/0-6	Copper	428 (220)

**NOTES:**

1. The multi-voltage transformer can supply two 480 V, 3-Phase, steam heated units, or one 480 V, 3-Phase, electric heated unit.
2. All connections should be in accordance with local codes.

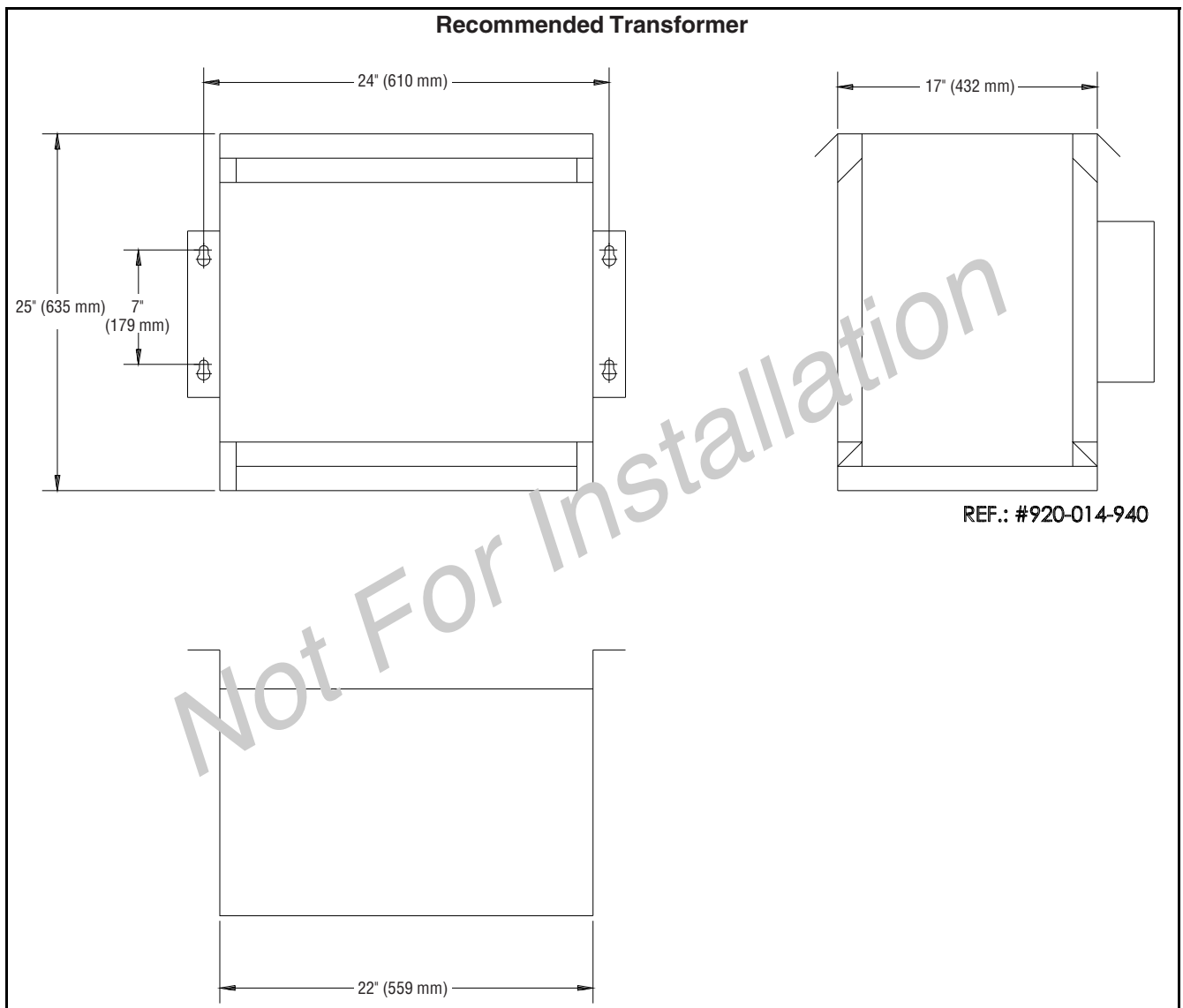

## NOTES

### Recommended Air Compressor

1. Enclosure must be well ventilated with a good air path to and from the ends of the compressor.
2. Inlet air temperature should be between 32° and 100°F (0° and 38°C). Locate air inlet outside of enclosed service areas. Inlet air pipe size is 1/4". Increase pipe diameter one size for every 10' (3048 mm) inlet filter is placed away from compressor.
3. Use 3/8" (or larger) pipe between compressor and washer/sterilizer when compressor is remotely located.
4. Air compressor, used in compliance with the Reliance 444 Single-Chamber Washer/Disinfector, can support one loading module and one unloading module (Reliance® Load/Unload Modules or Reliance® ATS Conveyor Direct Load and Direct Unload Modules).

## UTILITY REQUIREMENTS

### Recommended Air Compressor

#### Electrical - Compressor Motor

110-115 V, 50/60 Hz, 1-Phase,  
4.4 Amps;  
or  
200-240 V, 50/60 Hz, 1-Phase,  
1.4 Amps.

## ENGINEERING DATA - RECOMMENDED AIR COMPRESSOR WITH AUTOMATIC TANK DRAIN

AMP	HP	CFM Open Flow	Weight lbs (kg)	Comp. Stages	Cyl.	TANK				MOTOR	Noise Level
						Lubrication	Size in (mmO)	Capacity U.S. gal (L)	Max. Pressure psig (kPa)	Operating Speed Hz (rpm)	
1.4	1/3 (246)	2.0	42 (19)	1	1	Oilless	See Below	2.0 (7/6)	100 (690)	50 (1400) 60 (1675)	69 dBa

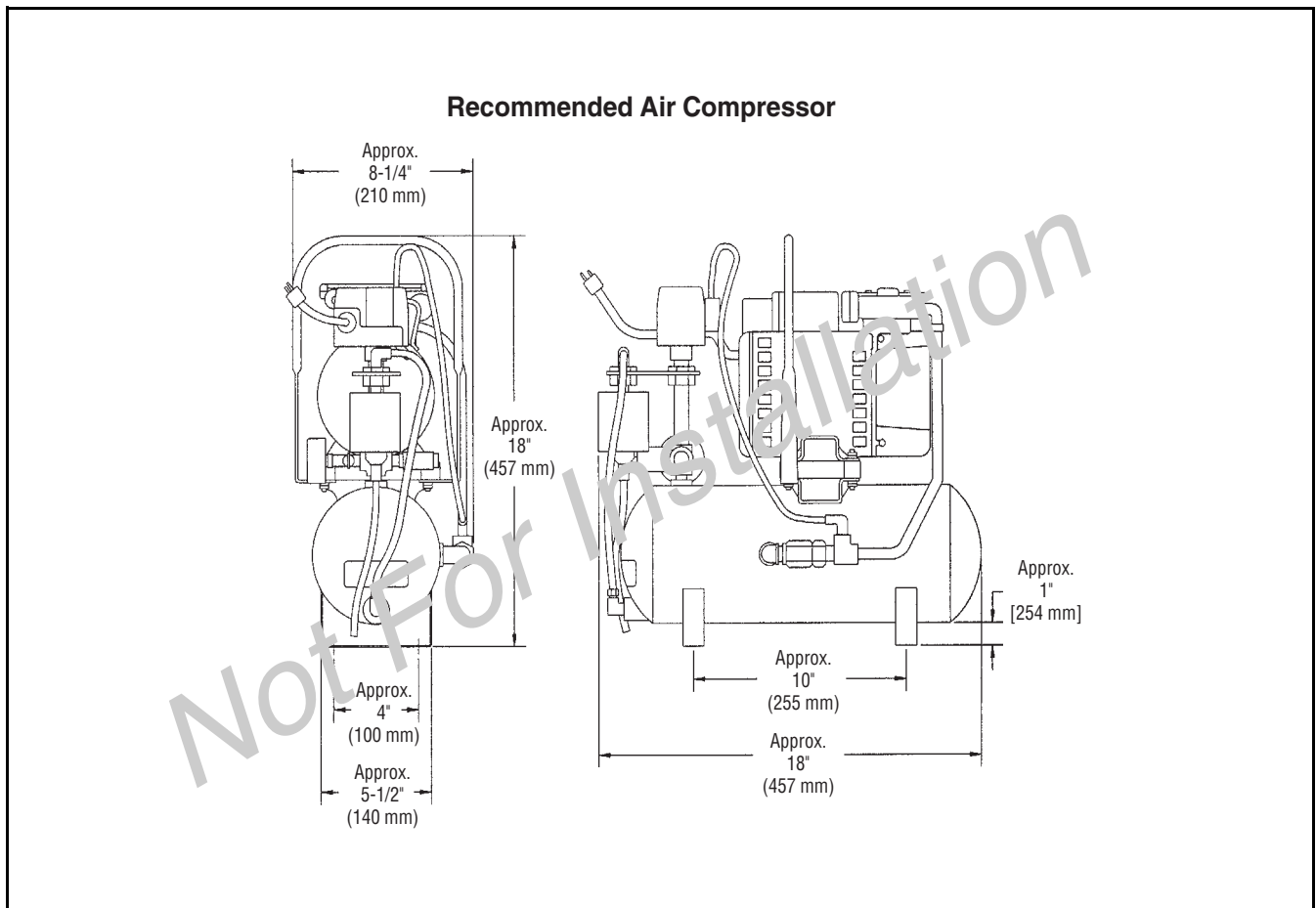

Reference the following equipment drawing for installation details.

Equip. Dwg. No.

Equipment Drawing Title

920-014-342EN

Reliance 444 Single-Chamber Washer/Disinfector 50HZ/60HZ - English

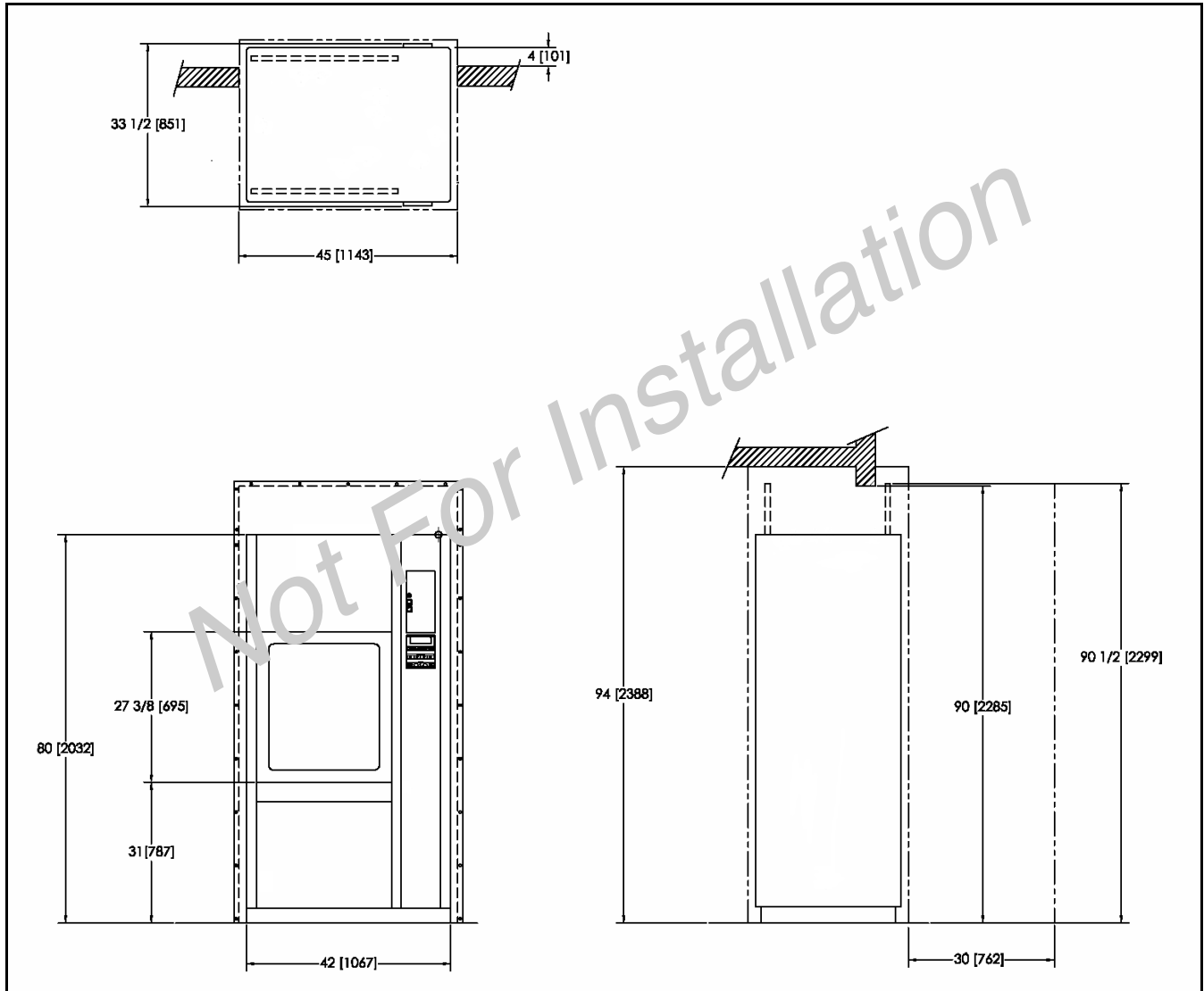

---

**For Further Information, contact:**

STERIS®



STERIS Corporation  
5960 Heisley Road  
Mentor, OH 44060-1834 • USA  
440-354-2600 • 800-548-4873  
[www.steris.com](http://www.steris.com)